



American Association of Physics Teachers

Ontario Section

# NEWSLETTER

Volume V, Number 1

Editor: Dean Gaily

September 1983

COMING ATTRACTION!!

**PLAN NOW!!**

**MARK THIS ONE DOWN!**

Sixth Annual AAPT-Ontario Conference

14-15-16 June, 1984 (Thurs. thru Sat.)

Royal Military College, Kingston, Ontario

OUTSTANDING STUDENT  
AWARD CERTIFICATE

**MEMBERSHIP RENEWALS**

AND

**NEW MEMBERSHIPS**

1983-84

On the mailing label for this Newsletter is the date of your membership expiration. To renew your membership or to become a member for the first time, complete the form below and send it along with the membership fee of \$5.00 (cheques payable to AAPT-Ontario) to:

John Hlynialuk  
Wiarnton District High School  
Box 580  
Wiarnton, Ontario N0H 2T0

NAME.....  
SCHOOL (UNIVERSITY).....  
ADDRESS.....  
CITY..... PROV.....  
POSTAL CODE..... RENEWAL..... NEW MEMBER.....

**AAPT-ONTARIO EXECUTIVE ('83-'84)**

President:

T. Dean Gaily, Physics, U.W.O.

Vice-President:

Brenda Molloy, Bayridge S.S., Kingston

Secretary-Treasurer:

John Hlynialuk, Wiarnton D.H.S.

Past President:

Ernie McFarland, Physics, Guelph Univ.

Section Representative:

Neves Pereira, Agincourt C.I.

Member-at-Large:

Eknath Marathé, Grantham H.S., St.Cath.

Archivist:

Doug Cunningham, Bruce Penn. D.H.S., Lions Hd.

Grade 11 Prize Editor:

Doug Fox, Belle River D.H.S.

**From the Editor:**

In assuming the reins of this publication from the able hands of George Kelly, (who is now enjoying life in Neuchatel, Switz. for a year) I am able to inflict a few of my own thoughts on you. The recent decision and hoopla from the Ministry regarding the deployment of microcomputers into every classroom and in fact at every student's desk in the near future causes me to stop and reflect a bit. In the April issue of "The Physics Teacher", Cliff Swartz also had cause to reflect on a similar but slightly different problem, although his suggestions are similar to my own thoughts. I quote:

"First, we have the crisis. Our students are not doing as well in science and math tests as students in other countries. Furthermore, they are not doing as well as they used to do here. The teachers of science and math are leaving the profession, and no new ones are being trained. In response to the crisis there are alarms and excursions. Now there are stirrings in the land. Out of Washington come rumors of crash programs and cash programs. Oh boy, oh boy, oh boy. Here we go again."

"Would you like to know how I would spend the money? I'm so glad you asked. As a guiding rule I would stay far away from high technology. Twenty years ago I claimed that television in schools was a waste of money and probably harmful. Today I feel the same way about computers. If you want kids to have computer literacy, do it on somebody else's nickel - not the science budget. Actually I don't even know what computer literacy means, and I suspect no one else does either. Perhaps it's something like typewriter literacy."

In a similar vein, Rod Grant, who just completed a 6 year term as Secretary of AAPT (Nat'l.), gave a paper at the recent Memphis meeting on "Finding Proper Roles for Computers in Physics Education". Here's his abstract:

"I have begun asking myself whether we have been forced to leave the 'Age of Reason' in order to enter the 'Age of Computers'. As access to computer hardware has become commonplace rather than elitist, the game-in-town has become euphemistically known as 'Computer Literacy'. What is meant by this term? Examples of thoughtful, clever, and even pedagogically useful applications of the computer are known. Nevertheless, the computer is often an add-on from the student's viewpoint; few examples of the successful integration of the computer into the physics curriculum are known. Likewise, evaluation which might suggest what has been gained or lost in the meantime is scarce. At this adolescent period in the development of uses of the computer in physics education, it seems appropriate to assess where we are, to outline the questions that remain before us, and to open for possible discussion examples of both proper and questionable uses of the computer."

Both of these highly respected physics educators are telling us the same thing - Let's go a little slowly into this 'Computer on every desk' scenario. Certainly computers are here to stay. I use one in my own research lab, and in my classroom teaching, wouldn't be without it, but I own it, not vice-versa. Today, too many of our students are enraptured by the keyboard and are oblivious to the physics. My suggestion: keep the physics content high, use the computer as a tool; we'll have stronger students as a result.

Dean Gaily

## SCIENCE DIMENSION

*The magazine about Canadian science.*

**FREE!**

**FREE!**

**FREE!**

Everyone likes something that is free. A glossy new magazine about science is offering a free first year subscription. It is called SCIENCE DIMENSION and it is about Canadian science. It is published six times a year and comes from the National Research Council. The first issue of thirty pages has brief news items, details of a sensitive mass spectrometer, cancer and immunology, root fungus, dulce (seaweed), aerodynamics of snowmobiles and air safety. The articles are interesting and well written. For your free subscription write to:

National Research Council  
Ottawa, Canada K1A 9Z9

**FIFTH ANNUAL AAPT ONTARIO CONFERENCE**

Hosted by the Physics Dept. at Waterloo, with details admirably handled by Ken Woolner, the fifth annual conference of AAPT-Ontario was held June 17 and 18, 1983. Starting off with the now famous reception and mixer on Thursday evening, the conference got under way Friday morning with the invited talk "The Discovery of the Compton Effect" by Roger Stuewer of the Univ. of Minnesota. This lively and extremely interesting presentation set the tone for a very stimulating and productive conference. Four contributed papers followed; Fluidized Bed Heat Exchanger Phenomenon - A Winter Driving Hazard by S. Ziauddin, Science Touring Through Britain by Don Stephen, Simple Speed of Light Experiment by Mats Selen and Innes MacKenzie and The September 1984 Science Guidelines by Brenda Molloy. A second invited talk, "Ontario Hydro's Nuclear Power Generation Program" by George Brenciaglia was next and then George Kelly, retiring president of the section, surprised everyone with "New Developments in Physics Teaching at the Provincial, National and International Level" which turned out to be a spirited and fast moving business meeting of the section. The announcement of the new members of the executive; Brenda Molloy, Vice-President and Eknath Marathe, Member-at-Large, shared the spotlight with the news of Ernie McFarland's nomination for the office of Vice-President of the National AAPT organization. The first day of the conference closed with the traditional "My Favourite Demonstration" and a review of selected physics software for microcomputers.

Our annual banquet was held in St. Jerome's College at Waterloo. An excellent meal was followed by an intensely detailed account of "The Events at Three Mile Island and Their Effects Upon the American People" by Les Ramsey of the Atomic International Forum, Washington D.C. Saturday morning four more contributed papers were heard; Measuring the Speed of Electrons in Solids with Microcurie Sources - A New Undergraduate Experiment by John Root and Innes MacKenzie, The Use of MX Notation to Simplify and Solve Problems Involving Many Variables by George Kelly, Introducing the Principles of Physics to Elementary Students by Doug Cunningham and Overview of Perspectives on Energy Program (AECL) by Danny Peirce. Next came Phil Eastman with "A Decade and a Half of SIN" and John Earnshaw "Jobs for Physics Grads", both invited talks. The conference ended with contributed papers Evaluating Physics Software by Paul McHoull, A Little Punk Rock for your General Levels by Bob Orrett and A Review of the AAPT-Ontario Grade 11 Prize Exam by Doug Fox.

**HIGH SCHOOL TEACHERS:**

**OUTSTANDING STUDENT  
AWARD CERTIFICATES**

- \*Honor your outstanding physics student  
- order this professionally printed certificate, signed by the President of AAPT
- \*Provide visibility for the physics teacher  
- have certificate signed by superintendent and principal
- \*Promote your physics program  
- use the sample press release included  
- present the certificate at a school assembly

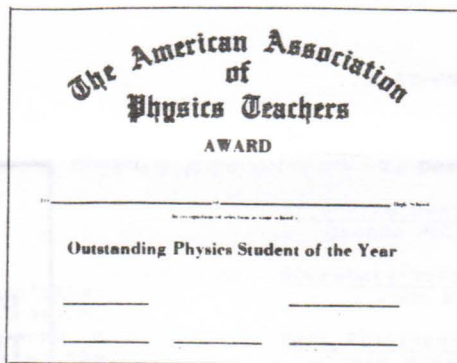

**Comments about the award:**

*From a physics teacher:*

"Let me take this opportunity to congratulate you and AAPT on the continued effort to encourage secondary physics students and teachers with the presentation of the Student Certificate Award. This award means so much to our students that we have made this award one of the highlights of our school awards ceremony . . ."

*From a physics student award recipient:*

"Thank you for presenting to me the outstanding physics student award. Your thoughtfulness was appreciated."

Available FREE. Order yours today:

Teacher's Name \_\_\_\_\_  
 (please print)  
 School Name \_\_\_\_\_  
 School Address \_\_\_\_\_  
 City \_\_\_\_\_ State \_\_\_\_\_ ZIP \_\_\_\_\_ Phone: \_\_\_\_\_

NOTE: Only one certificate per school is available.

Mail to: HIGH SCHOOL CERTIFICATES, American Association of Physics Teachers, Graduate Physics Building, SUNY Stony Brook, NY 11794.

## THE ACCELERATION DUE TO GRAVITY FOR \$1.39

One of the basic aims of education is to try to have the student do the experiments instead of seeing a demonstration. If you try to measure the acceleration due to gravity then you are talking big bucks for a classroom set of equipment. This article outlines how you can have your students do the experiment for about \$1.39 per lab station.

The equipment needed consists of a metre stick (the major expense), two small screw eyes, two nails, a ball bearing, talcumed marking tape<sup>1</sup> or carbon paper, masking tape, string and matches. Instead of a metre stick you could cut wood of the same length but it is a good opportunity to get rid of the old sticks with inches on one side.

Pairs of nails (about 30 cm apart) for each lab station are driven into the wood moulding above the chalkboard all around the room. The metre stick is the clock and the ball bearing is the falling object that we drop. To calibrate the clock the students are directed to let the stick swing freely with small amplitude and determine the period as the average time for ten swings. Another trial at larger amplitude shows the student that there is no difference in the period caused by the change in the amplitude. Now the equipment is arranged as in the diagram. One end of the string is taped to the ball. The string runs over the same nail that the stick is hung on and then over the second nail and down to the screw eye near the end of the stick. String can be saved if an extra half metre of string is at this end and then fed through the apparatus as string is used up in the various trials of the experiment. The metre stick has the talcumed tape or carbon paper on the side that faces the ball.

Now the experiment is performed. The centre of the ball is marked on the chalkboard. The string is burned at the point marked by the arrow. This causes the ball to fall and the metre stick to begin to swing at exactly the same time. The latter can be thought of as starting the clock. After one quarter of a swing the stick strikes the ball and the ball leaves a mark on the tape. The ball has fallen a vertical distance equal to the distance between the initial chalk mark on the board and the mark on the tape on the ruler when it is in the rest position. The fall occurs in a time equal to one quarter of the period of the pendulum. The formula  $g = 2a/t^2$  yields a decent value for  $g$ .

For a second and third trial the string is fed through the system and retaped to the ball. An average of three results can give  $g$  to within 5-10%. The best result comes from the case where the period is very well determined. This is done by accurate counting of fractions of a swing and letting the pendulum swing for a longer period of time.

An added bonus to this experiment can be achieved by using ball bearings of different mass. When the value determined for  $g$  is plotted against the ball bearing mass it becomes evident that there is no effect caused by the mass.

Doug Fox  
Belle River D.H.S.

<sup>1</sup>Available from most scientific suppliers. The tape is red but is covered by a layer of talcum on one side to make it white. When something hits or rubs on this side of the tape the talcum is removed and a red mark is left.

DIAGRAM

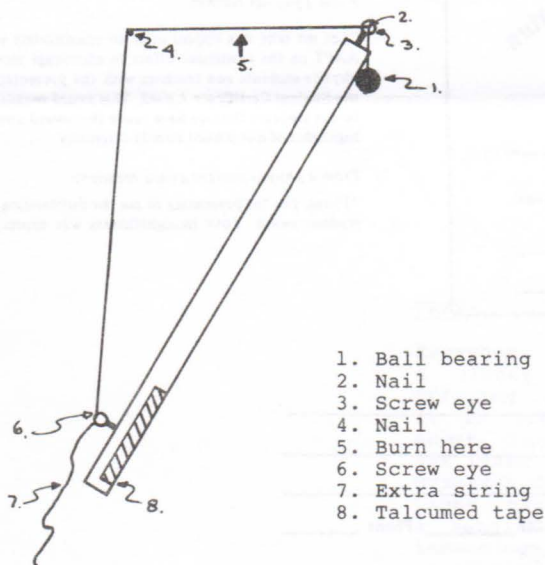

Teaching introductory physics without

## THE PHYSICS TEACHER

magazine

is like *taking a shower without soap*

While supplies last, we will send a FREE copy of a back issue of THE PHYSICS TEACHER so you can experience first-hand its

- helpful articles
- stimulating editorials
- unique columns
- informative book reviews

and much more.

To get your FREE issue and subscription information, send \$1 (to cover cost of mailing and handling)—and your own simile if you wish—to:

Back Numbers, THE PHYSICS TEACHER  
Department of Physics—SUNY  
Stony Brook, NY 11794